

100 Surgeries with one Meyco diamond knife?  
1.000 Surgeries with one Meyco diamond knife?

**You will not believe it –  
it can perform 10.000  
surgeries without resharpening!**



Swiss Diamond Technology  
[www.meyco.ch](http://www.meyco.ch)



It is the statement of Dr. A. Hennig, who built up the Lahan Eye Hospital in Nepal. They cannot afford expensive disposables – they work with valuable Meyco diamond knives.

You determine the life of your diamond knife. It never ever gets dull from cutting the cornea or sclera – just avoid any contact with other instruments.

## Do you know of any cheaper knife?

Meyco diamond knives with the high precision, fully titanium handle, are a true investment for long-term use.

# Meyco Diamond Knives since 1975

## Offering decades of use

Facts about diamond knives	4
Handles	5
Paracentesis incision diamond knives	6-8
Paracentesis diamond knives	9
Phaco incision diamond knives with sharp sides	10
3D Phaco incision diamond knives	11
Trapezoid phaco incision diamond knives	12
Phaco incision diamond knives with blunt sides	13-14
Crescent diamond knives	15
Multi purpose diamond knives to Dr. Zaldivar	15
Limbal relaxing incision diamond knives	16
Diamond knives for glaucoma surgery	17
Step diamond knives	18-20
Diamond knives for retinal surgery	21
Diamond knives with micrometer for refractive surgery	22
Diamond knives for kera rings and intacs implantation	23
Setting the micrometer dial and handling instructions for the micrometer knives	24
Correct handling instructions for the micrometer knives	25
Pre-delivery inspection	26
Instruction for use Meyco diamond scalpels	27
Meyco customer service	27



Swiss Diamond Technology  
[www.meyco.ch](http://www.meyco.ch)



## Facts about diamond knives

- Diamond blades are the sharpest scalpels available.
  - Diamond blades never get dull only damaged by improper use!
  - Diamond blades are the most economical cutting instruments available.
- 

### How long does a diamond blade last?

Since a diamond blade cannot get dull, it lasts theoretically forever. The blade gets damaged only if it touches an instrument, another hard object or if it falls to the floor.



Swiss Diamond Technology  
[www.meyco.ch](http://www.meyco.ch)

# Handles

The handles are made from titanium and are manufactured in Switzerland.  
We differentiate between the following handles:



Straight handle with pressure mechanism



J-slot mechanism

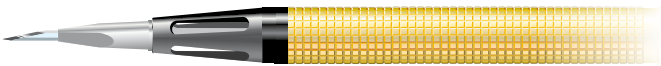

Straight handle with cleaning slits

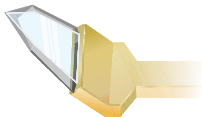

Angled

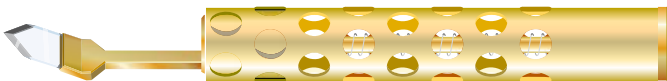

Angled handle with cleaning holes



Handle for step knives

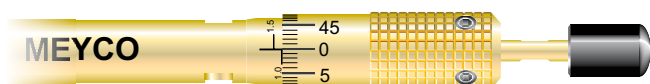

Handle for micrometer knives

# Paracentesis incision diamond knives



Handle with a straight mounting, pressure mechanism and cleaning slits



Handle with an angled mounting, j-slot mechanism

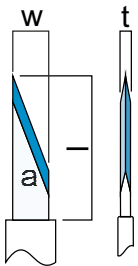

## Single edge 20°

width (w)	length (l)	thickness (t)	angle (a)	straight mounting	angled mounting
				order no:	order no:
0.50	3.50	0.20	20°	ME104DA	ME2104DA
1.00	3.50	0.20	20°	ME107	ME2107

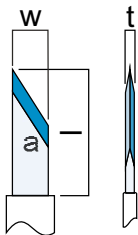
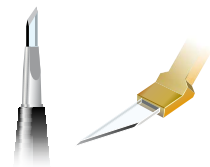

## Single edge 30°

width (w)	length (l)	thickness (t)	angle (a)	straight mounting	angled mounting
				order no:	order no:
1.00	3.50	0.20	30°	ME106	ME2106
1.50	3.50	0.20	30°	ME102	ME2102

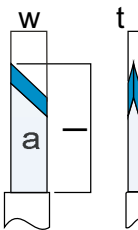

## Single edge 45°

width (w)	length (l)	thickness (t)	angle (a)	straight mounting	angled mounting
				order no:	order no:
0.80	3.50	0.20	45°	ME109	ME2109
1.00	3.50	0.20	45°	ME105	ME2105
1.50	3.50	0.20	45°	ME100	ME2100

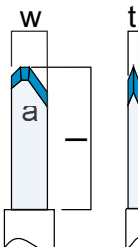
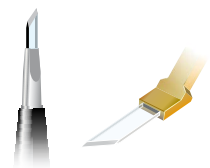

## Tri-facet

width (w)	length (l)	thickness (t)	straight mounting	angled mounting
			order no:	order no:
1.00	3.50	0.20	ME131	ME2131
1.50	3.50	0.20	ME130	ME2130



Please note: all handles are also available with cleaning holes (angled mounting) or cleaning slits (straight mounting). To order the knife with cleaning slits or cleaning holes please add a **C** behind the item number (e.g. **ME121-C**)

# Paracentesis incision diamond knives



Handle with a straight mounting, pressure mechanism and cleaning slits



Handle with an angled mounting, j-slot mechanism



**Ultra Sharp Series**  
blade thickness 100 micron only

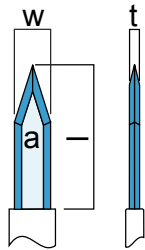

## Double lancet 30° sharp sides

width (w)	length (l)	thickness (t)	angle (a)	straight mounting	angled mounting
				order no:	order no:
0.90	3.50	0.10	30°	ME124-US30	ME2124-US30
1.00	3.50	0.10	30°	ME121-US30	ME2121-US30

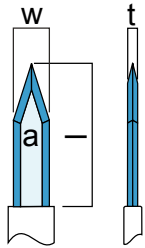
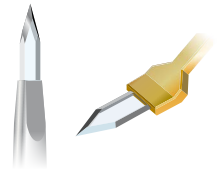

## Double lancet 30° sharp sides

width (w)	length (l)	thickness (t)	angle (a)	straight mounting	angled mounting
				order no:	order no:
1.00	3.50	0.20	30°	ME121-S30	ME2121-S30

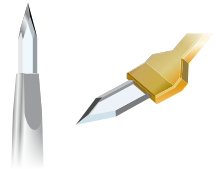

**Ultra Sharp Series**  
blade thickness 100 micron only

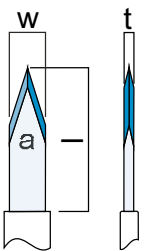

## Double lancet 30° blunt sides

width (w)	length (l)	thickness (t)	angle (a)	straight mounting	angled mounting
				order no:	order no:
0.80	3.50	0.10	30°	ME123-U30	ME2123-U30
0.90	3.50	0.10	30°	ME124-U30	ME2124-U30
1.00	3.50	0.10	30°	ME121-U30	ME2121-U30

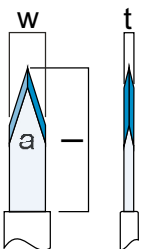
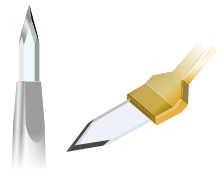

## Double lancet 30° blunt sides

width (w)	length (l)	thickness (t)	angle (a)	straight mounting	angled mounting
				order no:	order no:
0.80	3.50	0.20	30°	ME123-30	ME2123-30
0.90	3.50	0.20	30°	ME124-30	ME2124-30
1.00	3.50	0.20	30°	ME121-30	ME2121-30

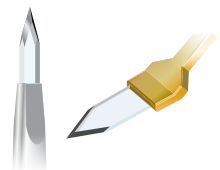

Please note: all handles are also available with cleaning holes (angled mounting) or cleaning slits (straight mounting). To order the knife with cleaning slits or cleaning holes please add a **C** behind the item number (e.g. **ME121-C**)

# Paracentesis incision diamond knives



Handle with a straight mounting, pressure mechanism and cleaning slits



Handle with an angled mounting, j-slot mechanism

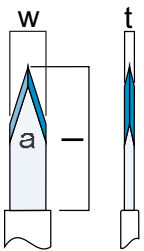

## Double lancet 40° blunt sides

width (w)	length (l)	thickness (t)	angle (a)	straight mounting order no:	angled mounting order no:
1.00	3.50	0.20	40°	ME122	ME2122

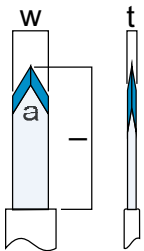
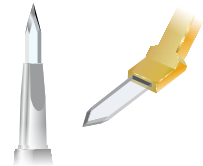

## Double lancet 60° blunt sides

width (w)	length (l)	thickness (t)	angle (a)	straight mounting order no:	angled mounting order no:
0.80	3.50	0.20	60°	ME123	ME2123
1.00	3.50	0.20	60°	ME121	ME2121
1.50	3.50	0.20	60°	ME120	ME2120

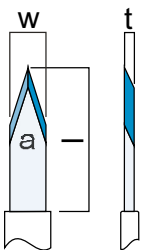
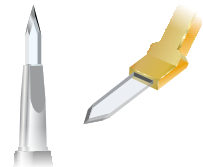

## Single lancet 40°

width (w)	length (l)	thickness (t)	angle (a)	straight mounting order no:	angled mounting order no:
0.80	3.50	0.20	40°	ME113	ME2113
1.00	3.50	0.20	40°	ME111	ME2111

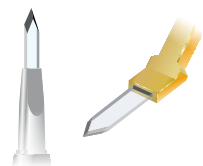

Please note: all handles are also available with cleaning holes (angled mounting) or cleaning slits (straight mounting). To order the knife with cleaning slits or cleaning holes please add a **C** behind the item number (e.g. **ME121-C**)



# Paracentesis diamond knives



Handle with a straight mounting  
and j-slot mechanism.  
Knives are available  
with or without cleaning holes

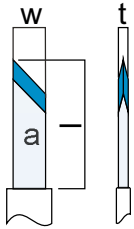
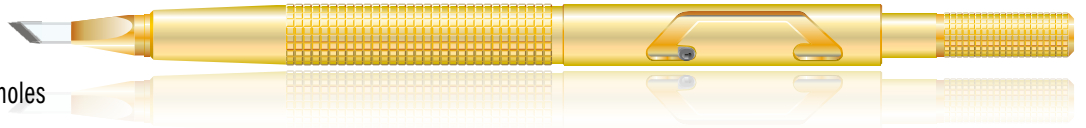

## Single edge 45°

width (w)	length (l)	thickness (t)	angle (a)	regular handle order no:	handle with cleaning holes order no:
1.00	3.50	0.20	45°	ME600	ME600-C

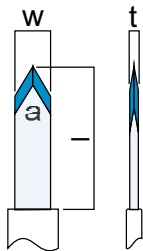

## Double lancet 60°

width (w)	length (l)	thickness (t)	angle (a)	regular handle order no:	handle with cleaning holes order no:
0.80	3.50	0.20	60°	ME610DA	ME610DA-C
1.00	3.50	0.20	60°	ME610	ME610-C
1.50	3.50	0.20	60°	ME613	ME613-C

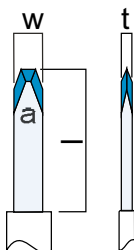

## Tri-facet

width (w)	length (l)	thickness (t)	angle (a)	regular handle order no:	handle with cleaning holes order no:
0.80	2.50	0.20		ME605	ME605-C

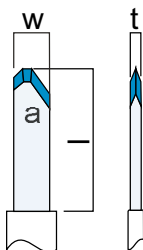

## Tri-facet

width (w)	length (l)	thickness (t)	angle (a)	regular handle order no:	handle with cleaning holes order no:
1.00	3.50	0.20		ME620	ME620-C



# Phaco incision diamond knives with sharp sides



Handle with an angled mounting, j-slot mechanism and cleaning holes



**Ultra Sharp Series**  
blade thickness 100 micron only

## Clear Corneal Double lancet 4mm with sharp sides 70°

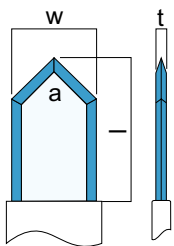

				regular handle	handle with cleaning holes
width (w)	length (l)	thickness (t)	angle (a)	order no:	order no:
2.20	4.00	0.10	70°	ME228DAU	ME228DAU-C
2.40	4.00	0.10	70°	ME230DAU	ME230DAU-C
2.50	4.00	0.10	70°	ME231DAU	ME231DAU-C
2.65	4.00	0.10	70°	ME232DAU	ME232DAU-C
2.75	4.00	0.10	70°	ME239DAU	ME239DAU-C
2.80	4.00	0.10	70°	ME233DAU	ME233DAU-C
2.85	4.00	0.10	70°	ME234DAU	ME234DAU-C
3.00	4.00	0.10	70°	ME235DAU	ME235DAU-C



## Clear Corneal Double lancet 4mm with sharp sides 70°

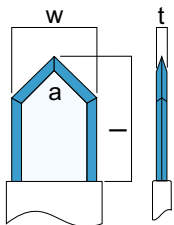

				regular handle	handle with cleaning holes
width (w)	length (l)	thickness (t)	angle (a)	order no:	order no:
1.80	4.00	0.20	70°	ME225DA	ME225DA-C
2.00	4.00	0.20	70°	ME227DA	ME227DA-C
2.20	4.00	0.20	70°	ME228DA	ME228DA-C
2.30	4.00	0.20	70°	ME229DA	ME229DA-C
2.40	4.00	0.20	70°	ME230DA	ME230DA-C
2.50	4.00	0.20	70°	ME231DA	ME231DA-C
2.65	4.00	0.20	70°	ME232DB	ME232DB-C
2.80	4.00	0.20	70°	ME233DA	ME233DA-C
2.85	4.00	0.20	70°	ME234DA	ME234DA-C
3.00	4.00	0.20	70°	ME235DA	ME235DA-C
3.10	4.00	0.20	70°	ME236DA	ME236DA-C
3.20	4.00	0.20	70°	ME237DA	ME237DA-C

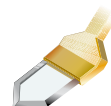

## Clear Corneal Double lancet 4mm with sharp sides 90°

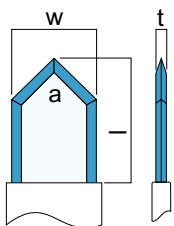

				regular handle	handle with cleaning holes
width (w)	length (l)	thickness (t)	angle (a)	order no:	order no:
1.80	4.00	0.20	90°	ME225	ME225-C
2.00	4.00	0.20	90°	ME227	ME227-C
2.20	4.00	0.20	90°	ME228	ME228-C
2.30	4.00	0.20	90°	ME229	ME229-C
2.40	4.00	0.20	90°	ME230	ME230-C
2.50	4.00	0.20	90°	ME231	ME231-C
2.65	4.00	0.20	90°	ME232	ME232-C
2.80	4.00	0.20	90°	ME233	ME233-C
2.85	4.00	0.20	90°	ME234	ME234-C
3.00	4.00	0.20	90°	ME235	ME235-C
3.10	4.00	0.20	90°	ME236	ME236-C
3.20	4.00	0.20	90°	ME237	ME237-C



# Phaco incision diamond knives with sharp sides



Handle with an angled mounting, j-slot mechanism and cleaning holes

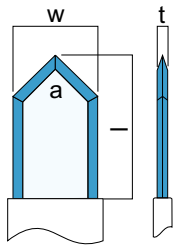

## Clear Corneal Double lancet 5mm with sharp sides 90°

width (w)	length (l)	thickness (t)	angle (a)	regular handle	handle with cleaning holes
				order no:	order no:
1.80	5.00	0.20	90°	ME238	ME238-C
2.20	5.00	0.20	90°	ME239	ME239-C
2.40	5.00	0.20	90°	ME240	ME240-C
2.65	5.00	0.20	90°	ME242	ME242-C
2.80	5.00	0.20	90°	ME243	ME243-C



## 3D Phaco incision diamond knives

Handle with an angled mounting, j-slot mechanism and cleaning holes

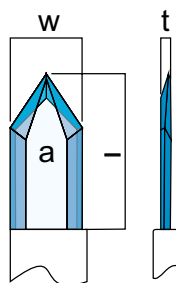

## Clear Corneal Navigator (3D knives) 4mm 80°

width (w)	length (l)	thickness (t)	angle (a)	regular handle	handle with cleaning holes
				order no:	order no:
1.80	4.00	0.20	80°	ME755	ME755-C
2.00	4.00	0.20	80°	ME757	ME757-C
2.20	4.00	0.20	80°	ME759	ME759-C
2.30	4.00	0.20	80°	ME760	ME760-C
2.40	4.00	0.20	80°	ME761	ME761-C
2.50	4.00	0.20	80°	ME272	ME272-C
2.60	4.00	0.20	80°	ME272DA	ME272DA-C
2.65	4.00	0.20	80°	ME273	ME273-C
2.80	4.00	0.20	80°	ME274	ME274-C
2.85	4.00	0.20	80°	ME274DA	ME274DA-C
3.00	4.00	0.20	80°	ME275	ME275-C



Please note: all handles are also available without cleaning holes.

# 3D Phaco incision diamond knives



Handle with an angled mounting, j-slot mechanism and cleaning holes

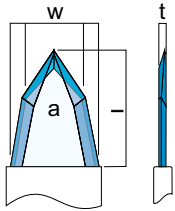

## Clear Corneal Double lancet, trapezoid (3D knife) 4mm with sharp sides 80°

width (w)	length (l)	thickness (t)	angle (a)	regular handle	handle with cleaning holes
				order no:	order no:
2.5 - 3.5	4.00	0.20	80°	ME200-P14	ME200-P14-C



## Trapezoid phaco incision diamond knives

Handle with an angled mounting, j-slot mechanism and cleaning holes

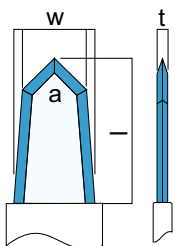

## Clear Corneal Double lancet, trapezoid 4mm with sharp sides 80°

width (w)	length (l)	thickness (t)	angle (a)	regular handle	handle with cleaning holes
				order no:	order no:
1.40 - 1.60	4.00	0.20	80°	ME276	ME276-C
1.60 - 1.80	4.00	0.20	80°	ME276DA	ME276DA-C
1.80 - 2.00	4.00	0.20	80°	ME276DB	ME276DB-C
1.80 - 2.20	4.00	0.20	80°	ME277	ME277-C
1.80 - 2.40	4.00	0.20	80°	ME277DA	ME277DA-C
2.50 - 2.80	4.00	0.20	80°	ME278	ME278-C
2.75 - 2.90	4.00	0.20	80°	ME279	ME279-C

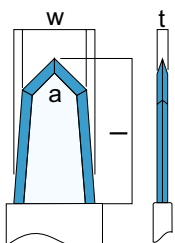

## Clear Corneal Double lancet, trapezoid 4mm with sharp sides 90°

width (w)	length (l)	thickness (t)	angle (a)	regular handle	handle with cleaning holes
				order no:	order no:
1.10 - 1.40	2.50	0.20	90°	ME772DA	ME772DA-C



Please note: all handles are also available without cleaning holes.

# Phaco incision diamond knives with blunt sides



Handle with an angled mounting, j-slot mechanism and cleaning holes



**Ultra Sharp Series**  
blade thickness 100 micron only

## Clear Cornea Double lancet 4mm with blunt sides 70°

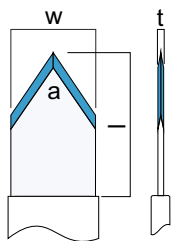

width (w)	length (l)	thickness (t)	angle (a)	regular handle	handle with cleaning holes
				order no:	order no:
2.20	4.00	0.10	70°	ME213DAU	ME213DAU-C
2.40	4.00	0.10	70°	ME213U	ME213U-C
2.50	4.00	0.10	70°	ME214U	ME214U-C
2.65	4.00	0.10	70°	ME215U	ME215U-C
2.75	4.00	0.10	70°	ME204U	ME204U-C
2.80	4.00	0.10	70°	ME216U	ME216U-C
2.85	4.00	0.10	70°	ME217U	ME217U-C
3.00	4.00	0.10	70°	ME218U	ME218U-C



## Clear Cornea Double lancet 4mm with blunt sides 70°

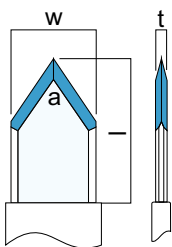

width (w)	length (l)	thickness (t)	angle (a)	regular handle	handle with cleaning holes
				order no:	order no:
2.20	4.00	0.20	70°	ME200	ME200-C
2.30	4.00	0.20	70°	ME201	ME201-C
2.40	4.00	0.20	70°	ME202	ME202-C
2.50	4.00	0.20	70°	ME203	ME203-C
2.65	4.00	0.20	70°	ME205	ME205-C
2.75	4.00	0.20	70°	ME206	ME206-C
2.80	4.00	0.20	70°	ME206DA	ME206DA-C
2.85	4.00	0.20	70°	ME207	ME207-C
3.00	4.00	0.20	70°	ME208	ME208-C
3.10	4.00	0.20	70°	ME209	ME209-C

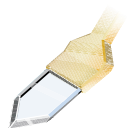

Please note: all handles are also available without cleaning holes.

# Phaco incision diamond knives with blunt sides



Handle with an angled mounting, j-slot mechanism and cleaning holes



## Clear Cornea Single lancet 4mm with blunt sides 70°

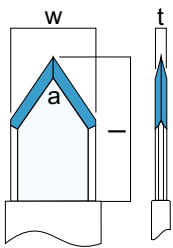

width (w)	length (l)	thickness (t)	angle (a)	regular handle	handle with cleaning holes
				order no:	order no:
2.20	4.00	0.20	70°	ME213DA	ME213DA-C
2.30	4.00	0.20	70°	ME213DB	ME213DB-C
2.40	4.00	0.20	70°	ME213	ME213-C
2.50	4.00	0.20	70°	ME214	ME214-C
2.65	4.00	0.20	70°	ME215	ME215-C
2.80	4.00	0.20	70°	ME216	ME216-C
2.85	4.00	0.20	70°	ME217	ME217-C
3.00	4.00	0.20	70°	ME218	ME218-C
3.10	4.00	0.20	70°	ME219	ME219-C

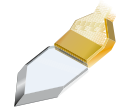

Please note: all handles are also available without cleaning holes.

# Crescent diamond knives



Handle with an angled mounting, j-slot mechanism and cleaning holes

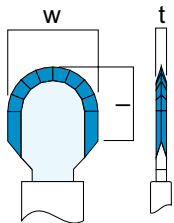

## Crescent diamond knife with sharp sides

width (w)	length (l)	thickness (t)	regular handle	handle with cleaning holes
			order no:	order no:
2.50	3.50	0.20	ME280	ME280-C

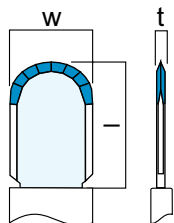
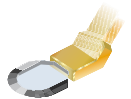

## Crescent diamond knives with blunt sides

width (w)	length (l)	thickness (t)	regular handle	handle with cleaning holes
			order no:	order no:
1.00	4.00	0.20	ME281DA	ME281DA-C
2.50	4.00	0.20	ME281	ME281-C

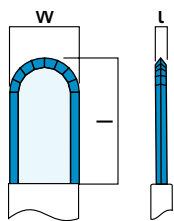
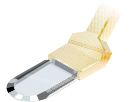

## Tunnel diamond knives with sharp sides

width (w)	length (l)	thickness (t)	regular handle	handle with cleaning holes
			order no:	order no:
1.50	4.00	0.20	ME284	ME284-C
2.00	4.00	0.20	ME285	ME285-C

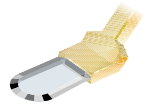

# Multi purpose diamond knives to Dr. Zaldivar

Step cut, scleral tunnel incision, opening the anterior chamber, wound widening for IOL implantation

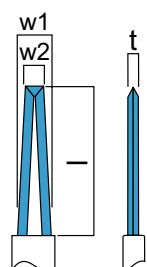

width (w) 1	width (w) 2	length (l)	thickness (t)	regular handle	handle with cleaning holes
				order no:	order no:
1.00	0.55	4.50	0.15	ME297	ME297-C



Please note: all handles are also available without cleaning holes.

# Limbal relaxing incision diamond knives



## Micrometer knife with one side footplate for better control

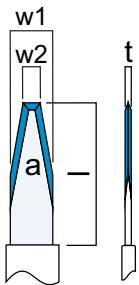

width (w) 1	width (w) 2	length (l)	thickness (t)	angle (a)	regular handle
1.00	0.40	3.00	0.10	20°	order no: ME435



## Preset step knives with 1 setting

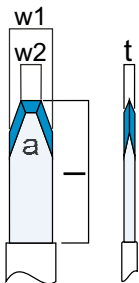

preset at	width (w) 1	width (w) 2	length (l)	thickness (t)	angle (a)	regular handle
0.50	1.00	0.40	2.00	0.20	40°	order no: ME709
0.55	1.00	0.40	2.00	0.20	40°	order no: ME704
0.60	1.00	0.40	2.00	0.20	40°	order no: ME700
0.65	1.00	0.40	2.00	0.20	40°	order no: ME701



## Preset step knife with 3 settings: 0.50 / 0.55 / 0.60

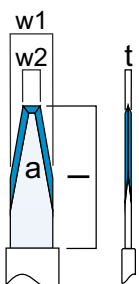

width (w) 1	width (w) 2	length (l)	thickness (t)	angle (a)	regular handle
1.00	0.40	3.00	0.10	40°	order no: ME707





# Diamond knives for glaucoma surgery

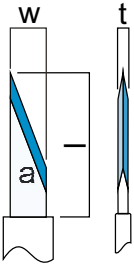

## Single edge 20° handle with pressure mechanism

width (w)	length (l)	thickness (t)	angle (a)	regular handle	handle with cleaning slits
0.50	3.50	0.20	20°	ME104DA	ME104DA-C

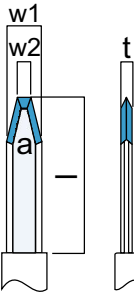

## Step knife to Dr. Carassa

(cutting depth: 0.15 / 0.20 / 0.25 / 0.30 / 0.37 / 0.50 / 4.00)

width (w1)	width (w2)	length (l)	thickness (t)	angle (a)	regular handle
1.00	0.30	3.50	0.20	25°	ME312

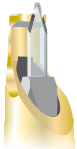

# Step diamond knives



The diamond knives with preselectable cutting depths; a guarantee for optimum cutting security.  
 The one sided footplate allows an optimum viewing of the diamond blade. The step diamond knife is a Meyco innovation which has been manufactured since 1987.  
 The standard actuation is for right hand execution; left hand is also available.

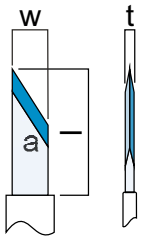

## Step knife single edge 30°

(cutting depth: 0.15 / 0.20 / 0.25 / 0.30 / 0.37 / 0.50 / 4.00)

width (w)	length (l)	thickness (t)	angle (a)	order no:	regular handle
1.00	3.50	0.20	30°	ME302	

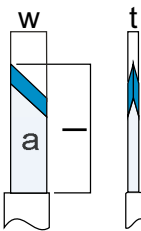

## Step knife single edge 45°

(cutting depth: 0.15 / 0.20 / 0.25 / 0.30 / 0.37 / 0.50 / 4.00)

width (w)	length (l)	thickness (t)	angle (a)	order no:	regular handle
1.00	3.50	0.20	45°	ME300	

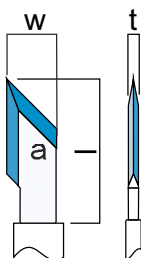

## Step knife 2 facets 45°

(cutting depth: 0.15 / 0.20 / 0.25 / 0.30 / 0.37 / 0.50 / 4.00)

width (w)	length (l)	thickness (t)	angle (a)	order no:	regular handle
1.40	3.50	0.20	45°	ME305	



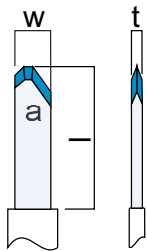

## Step knife 3 facets

(cutting depth: 0.15 / 0.20 / 0.25 / 0.30 / 0.37 / 0.50 / 4.00)

width (w)	length (l)	thickness (t)	angle (a)	regular handle	order no:
1.00	3.50	0.20	45°		ME310

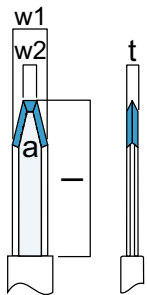

## Step knife to Dr. Carassa

(cutting depth: 0.15 / 0.20 / 0.25 / 0.30 / 0.37 / 0.50 / 4.00)

width (w1)	width (w2)	length (l)	thickness (t)	angle (a)	regular handle	order no:
1.00	0.30	3.50	0.20	25°		ME312

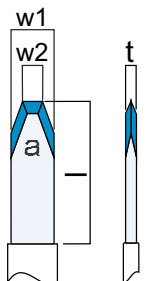

## Step knife 3 facets

(cutting depth: 0.3 / 0.6)

width (w1)	width (w2)	length (l)	thickness (t)	angle (a)	regular handle	order no:
1.00	0.40	4.00	0.20	40°		ME300-P7

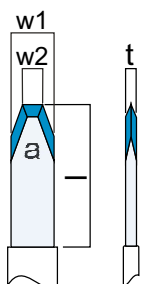
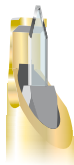

## Step knife 3 facets

(cutting depth: 0.15 / 0.20 / 0.25 / 0.30 / 0.37 / 0.50 / 4.00)

width (w1)	width (w2)	length (l)	thickness (t)	angle (a)	regular handle	order no:
1.00	0.40	4.00	0.20	40°		ME300-P7MA



# Step diamond knives

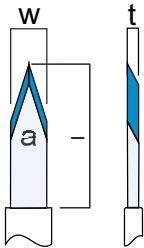

## Step knife single lancet 40°

(cutting depth: 0.15 / 0.20 / 0.25 / 0.30 / 0.37 / 0.50 / 4.00)

regular handle

width (w)	length (l)	thickness (t)	angle (a)	order no:
1.00	3.50	0.20	40°	ME315

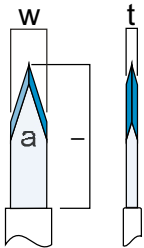

## Step knife double lancet 60°

(cutting depth: 0.15 / 0.20 / 0.25 / 0.30 / 0.37 / 0.50 / 4.00)

regular handle

width (w)	length (l)	thickness (t)	angle (a)	order no:
1.00	3.50	0.20	60°	ME317

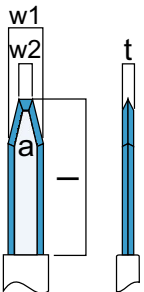

## Step knife to Dr. Osher

(cutting depth: 0.15 / 0.20 / 0.25 / 0.30 / 0.37 / 0.50 / 4.00)

regular handle

width (w1)	width (w2)	length (l)	thickness (t)	angle (a)	order no:
1.00	0.40	3.50	0.20	45°	ME318

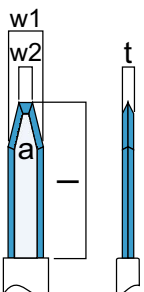

## Step knife to Dr. Osher

(cutting depth: 0.30 / 0.60 / 4.0)

regular handle

width (w1)	width (w2)	length (l)	thickness (t)	angle (a)	order no:
1.00	0.40	3.50	0.20	45°	ME318MA



# Diamond knives for retinal surgery

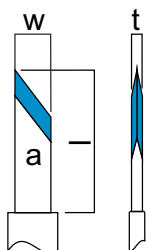

## Retina diamond knife to Dr. Molfetta for cutting subretinal membranes.

width (w)	length (l)	thickness (t)	angle (a)	regular handle order no:
0.90	3.00	0.20	45°	ME502

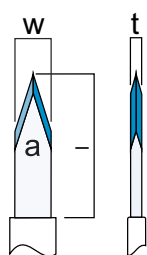

## Double lancet diamond knife for vitrectomy surgery to cut the vein

width (w)	length (l)	thickness (t)	angle (a)	regular handle order no:
0.50	2.00	0.10	40°	ME527



# Diamond knives with micrometer for refractive surgery



The high precision instrument that has proven itself thousands of times over the years with its unique advantages: a micrometer of the highest precision, with an easy legible black scale a footplate that allows the best possible view on the diamond blade, with absolutely parallel footplates, which guarantee that the set cutting depth is precisely reached. A superfine polished right angle (a) footplate which glides very smoothly over the cornea simple pressure mechanism range: 0 - 1.50 mm

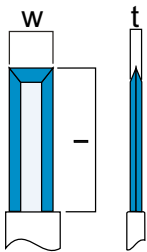

## RK diamond knife

width (w)	length (l)	thickness (t)	regular handle	order no:
1.00	3.00	0.20		ME420

corresponding measuring gauge ME459

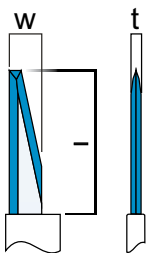

## RK diamond knife to Dr. Thornton

width (w)	length (l)	thickness (t)	angle (a)	regular handle	order no:
0.80	3.50	0.10	15°		ME425

corresponding measuring gauge ME459

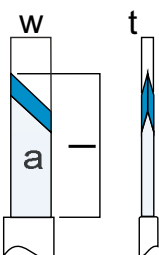

## Double edge 45° RK diamond knives

width (w)	length (l)	thickness (t)	angle (a)	regular handle	order no:
1.00	3.50	0.20	45°		ME450
1.00	3.50	0.10	45°		ME451

corresponding measuring gauge ME459



# Diamond knives with micrometer for refractive surgery

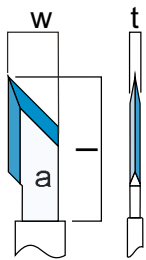

## RK diamond knives double edge

width (w)	length (l)	thickness (t)	angle (a)	regular handle order no:
1.40	3.50	0.20	45°	ME400
1.40	3.50	0.10	45°	ME401

corresponding measuring gauge ME409

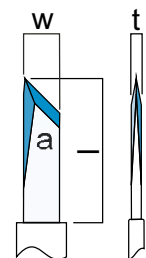

## RK diamond knives 2 facets

width (w)	length (l)	thickness (t)	angle (a)	regular handle order no:
1.00	3.50	0.10	45°	ME410
1.00	3.50	0.20	45°	ME411

corresponding measuring gauge ME459



## Diamond knives for Kera Rings and Intacs implantation

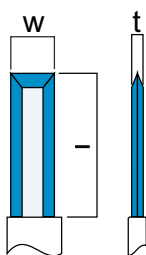

## Micrometer diamond knives to perform a small incision in the surface of the cornea

width (w)	length (l)	thickness (t)	regular handle order no:
0.80	3.50	0.10	ME400-P3
1.00	3.50	0.20	ME420MA

corresponding measuring gauge ME459

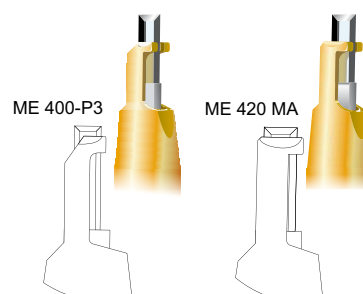

# Setting the micrometer dial

1. If the guidance line is visible the push button may be pressed gently
2. If the guidance line is not visible, the push button must not be pressed
3. The push button must always be pressed gently. Never with force! If it is pressed with force the inside sapphire bullet breaks which makes the knife unusable.

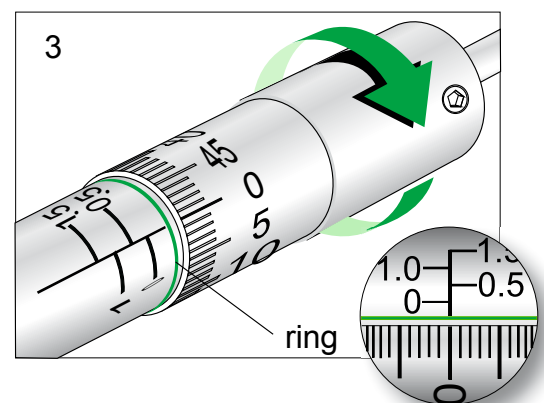
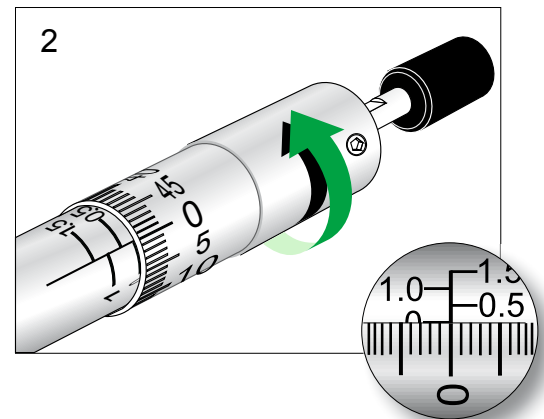
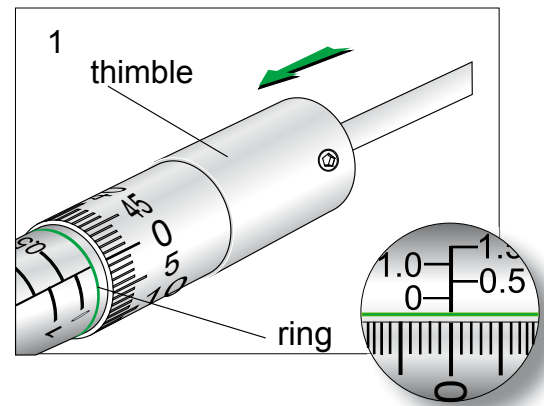

## Measuring gauge;

- Turn the micrometer dial to the 2nd marker ring
- Hold the blade upright and activate the pressure mechanism
- Turn the micrometer dial to zero – the tip of the diamond blade should be level with the guide shoe.
- Set the required cutting depth  
1 turn = 0.50 mm

We recommend that the cutting depth should be checked. The cutting depth can be measured using an ME409 (for DK-Blades double edged) or ME459 (for M-Blades single edged) device.

Measuring gauge for checking the depth of incision setting

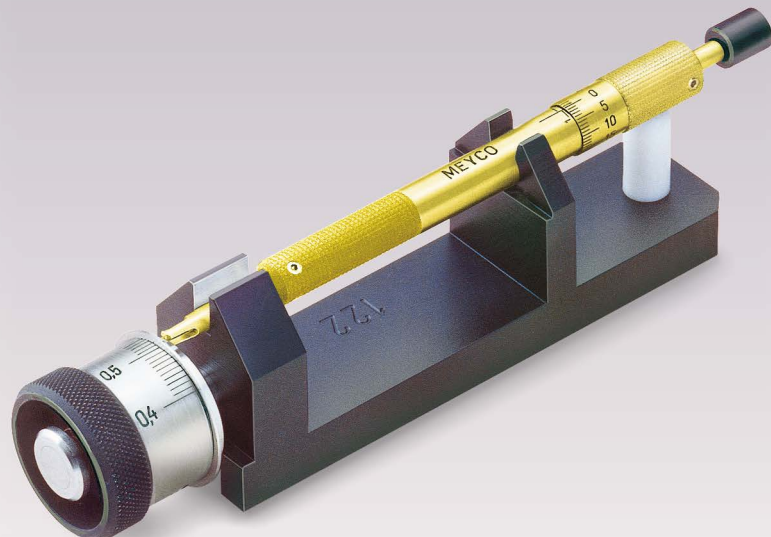



# Correct handling instructions for the micrometer knives

1. If the guidance line is visible the push button may be pressed gently
2. If the guidance line is not visible, the push button must not be pressed
3. The push button must always be pressed gently. Never with force! If it is pressed with force the inside sapphire bullet breaks which makes the knife unusable.

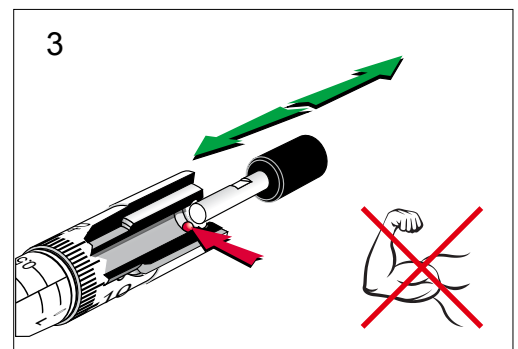
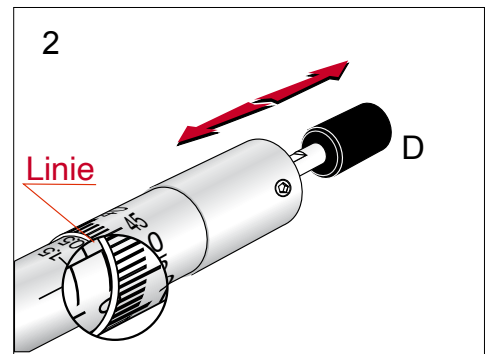
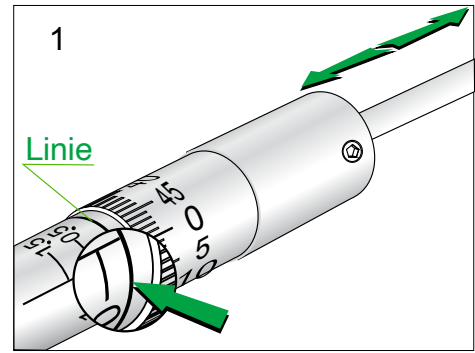

**READ  
CAREFULLY**

# Pre-delivery inspection

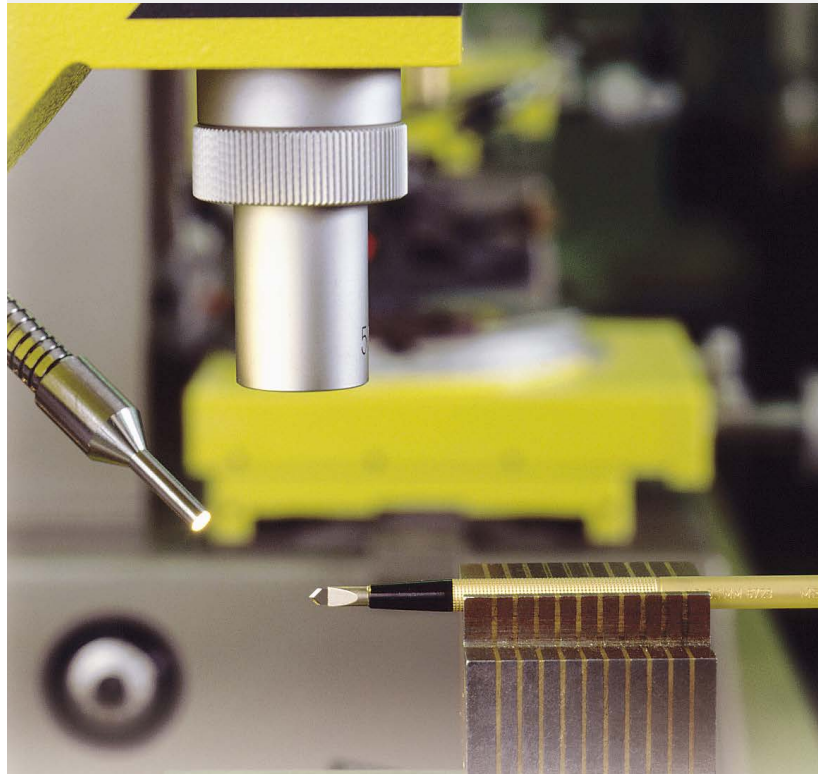

Only diamond, as the hardest known material, can be grind so smoothly that it's cutting edge is still perfect under 500x magnification. Each Meyco diamond blade is checked under this magnification after the final grinding.

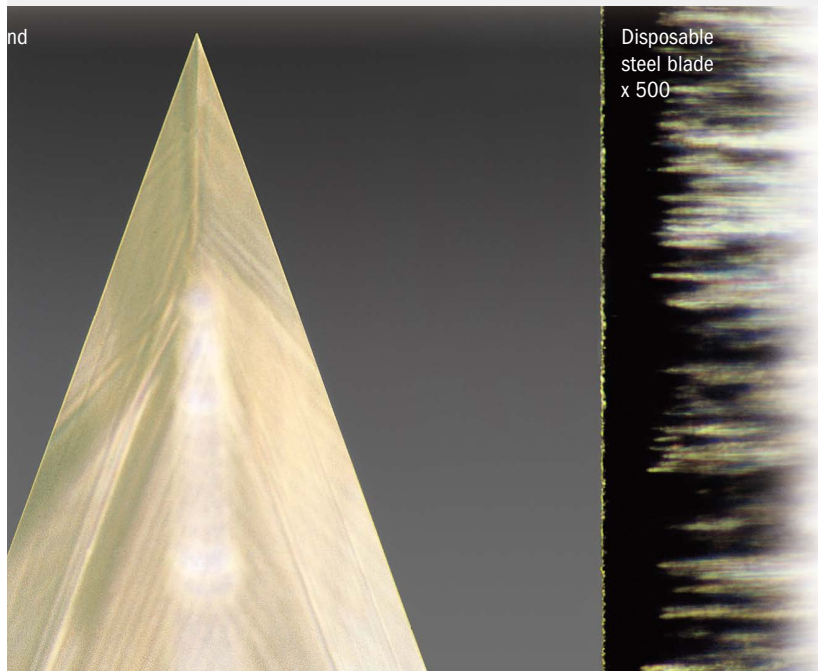

According to the Rosiwal scale, a diamond has an abrasive hardness of 140 times that of sapphire and ruby (corundum). This explains why the cornea can be cut so smoothly with a perfectly grind diamond.

# Instructions for use

# Meyco customer service

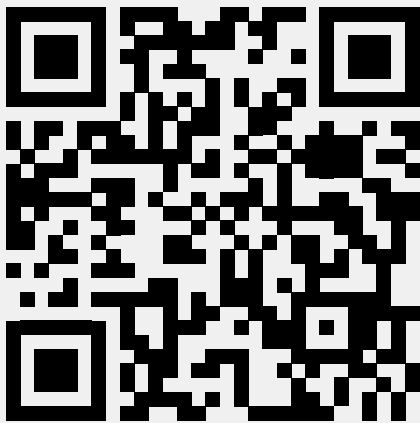
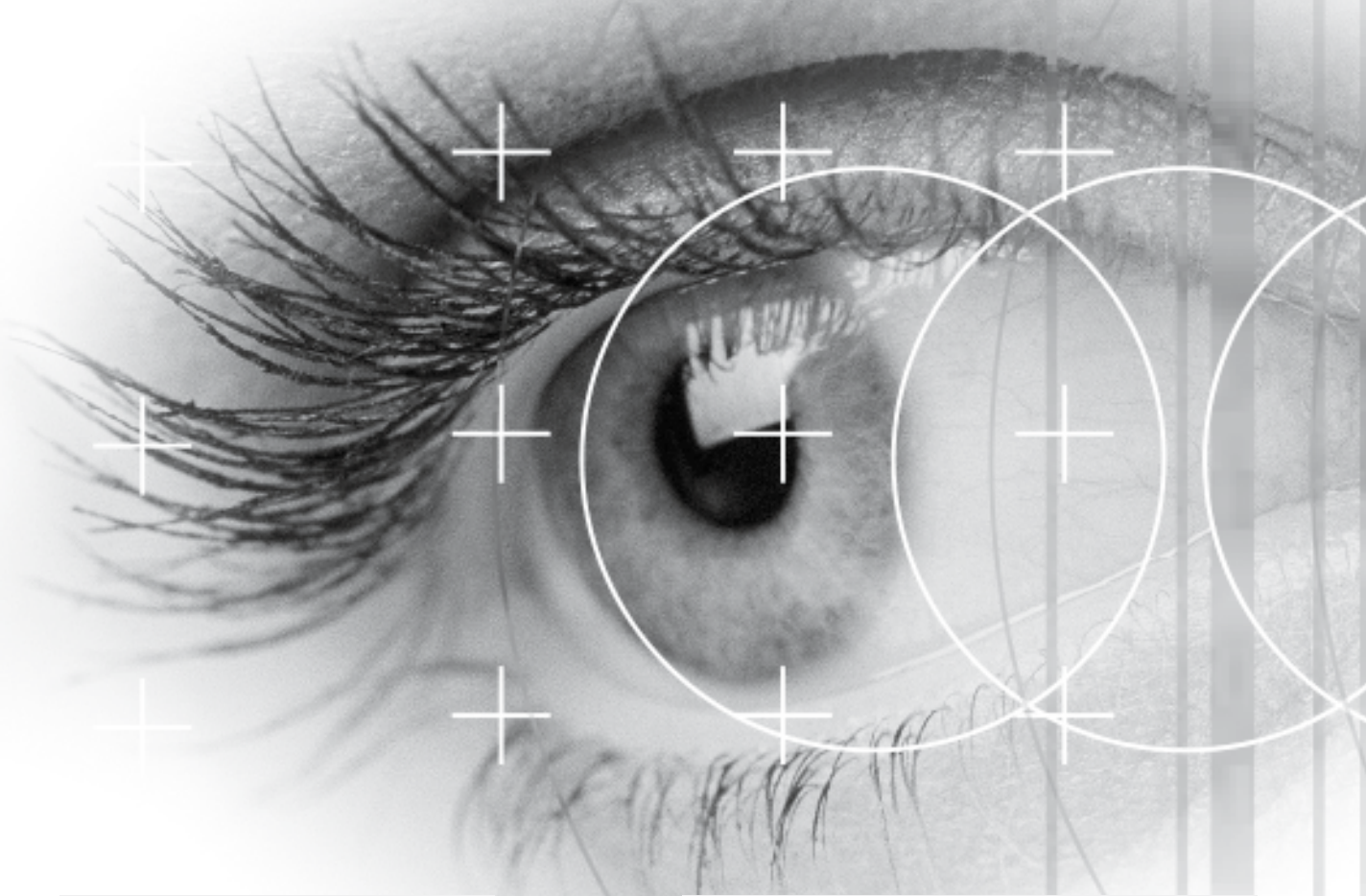

Find the current IFU here:  
[www.meyco.ch](http://www.meyco.ch)

Most of our diamond blades can be resharpened several times (except ME-425) if they are not too severely damaged.

For each repair, the handle is totally dismantled. All mechanical parts are cleaned, checked and replaced if necessary. Micrometer and step knives are recalibrated.

After grinding, the diamond blade is checked at the same standard as new knives.

We always do our best in order to return your repairs as soon as possible.

However, the lead time may vary due to the many different kind of blade types we receive for resharpening.



Swiss quality production

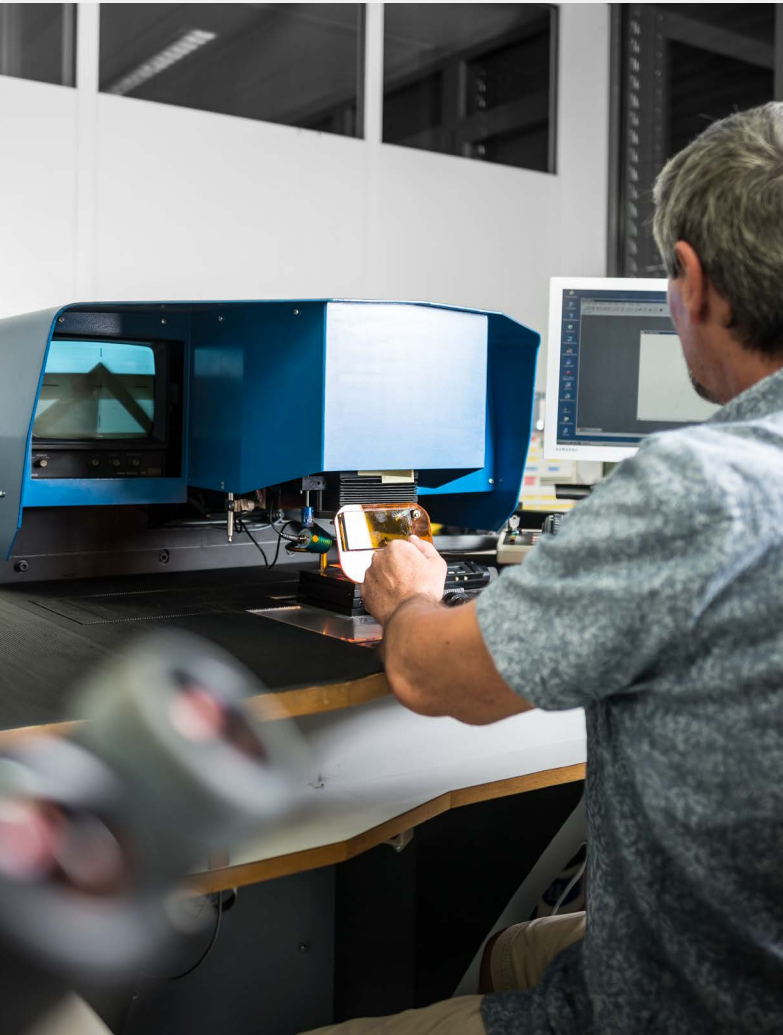

The shape of the blades is cut with a Yag laser.



Most mechanical parts are made from Titanium, manufactured on high precision CNC machines. Meyco diamond knives can therefore be sterilized by any conventional method.

ANTON MEYER & CO LTD  
Helmstrasse 1  
CH-2560 Nidau, Switzerland

Tel. 41 32 332 91 11  
Fax 41 32 331 52 57  
Internet <http://www.meyco.ch>  
E-mail [meyco@meyco.ch](mailto:meyco@meyco.ch)



Swiss Diamond Technology  
[www.meyco.ch](http://www.meyco.ch)